

Chain Size	Pitch		Dimensions					Average U.T.S
	P	A	B	C	D	E		
CC600	2.50"	1.18"	0.51"	0.91"	0.44"	1.73"	14600 lbs	
	63.5	30	13	23	11.1	44	65KN	

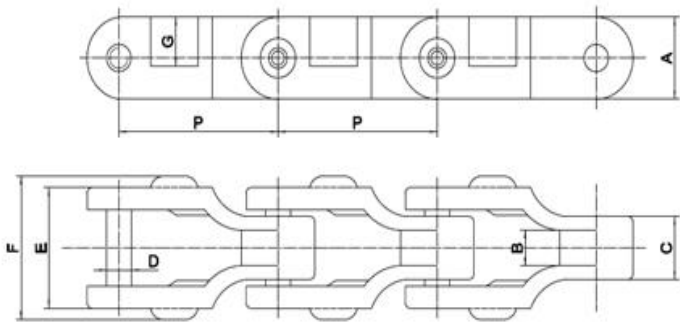

Chain Size	Pitch		Dimensions							Average U.T.S
	P	A	B	C	D	E	F	G		
CC600D	2.50"	1.18"	0.51"	0.91"	0.44"	1.73"	2.13"	0.71"	14600 lbs	
	63.5	30	13	23	11.1	44	54	18	65KN	

NOTE: Please consult with Camel Convey for requirements for not listed above.

Email: [sales@camelconvey.com](mailto:sales@camelconvey.com)  
[www.camelconvey.com](http://www.camelconvey.com)

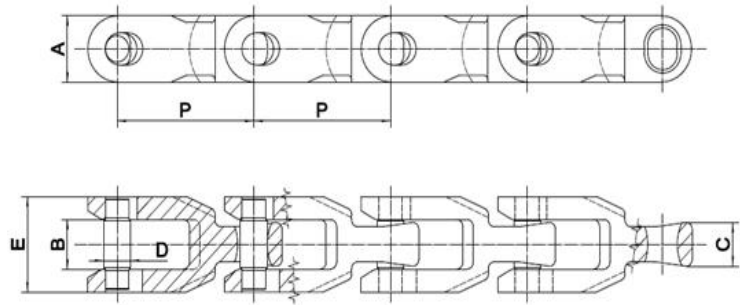

Chain Size	Pitch		Dimensions					Average U.T.S
	P	A	B	C	D	E		
F801	2.73"	1.18"	0.89"	0.83"	0.54"	1.71"	16800 lbs	
	69.35	30	22.5	21	13.6	43.5	75KN	

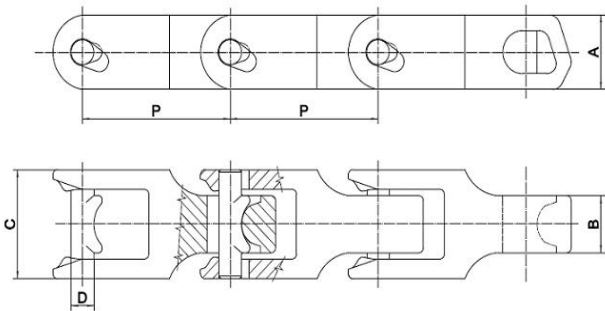

Chain Size	Pitch		Dimensions				Average U.T.S
	P	A	B	C	D		
MC33	2.488"	1.26"	0.69"	1.5"	0.47"	11000 lbs	
	63.2	32	17.5	38.1	12	49 KN	

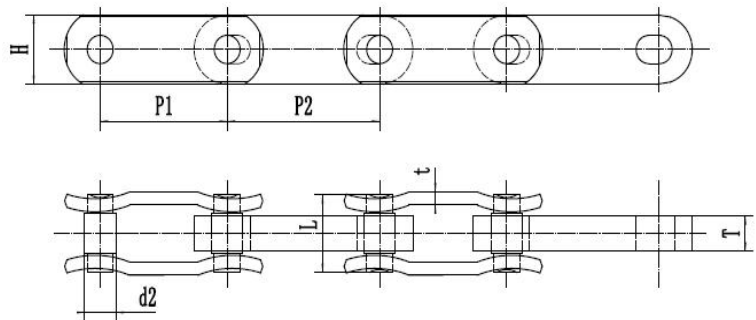

Chain Size	Pitch		Dimensions						Average U.T.S
	P1	P2	H	T	t	d2	L	R	
DF3500	2.5"	3"	1.25"	0.625"	0.25"	0.57"	1.4"	<20"	47250 lbs
	63.5	76.2	31.75	15.88	6.35	14.5	35.5	<508	210KN

NOTE: Please consult with Camel Convey for requirements for not listed above.

Email: [sales@camelconvey.com](mailto:sales@camelconvey.com)  
[www.camelconvey.com](http://www.camelconvey.com)

## I Series Pintle Chain With K1/K2 Attachment

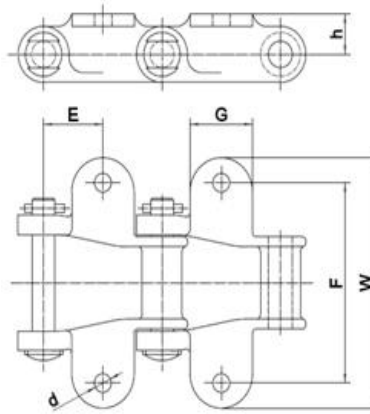

Chain No.	Pitch		Dimensions				
	P	h	G	E	d	F	W
H60	2.308"	0.75"	1.13"	1.06"	0.31"	3"	4"
	58.62mm	19.05mm	28.7mm	26.9mm	7.9mm	76.2mm	101.6mm
H78	2.609"	0.69"	1.13"	1.25"	0.31"	2.88"	3.88"
	66.27mm	17.5mm	28.7mm	31.75mm	7.9mm	73.15mm	98.55mm
H82	3.075"	0.81"	1.38"	1.25"	0.38"	4"	5"
	78.1mm	20.58mm	35mm	31.75mm	9.65mm	101.6mm	127mm
H124	4"	1.19"	2.87"	1.89"	0.38"	5.25"	6.38"
	101.6mm	30.2mm	72.9mm	48mm	9.65mm	133.4mm	162mm

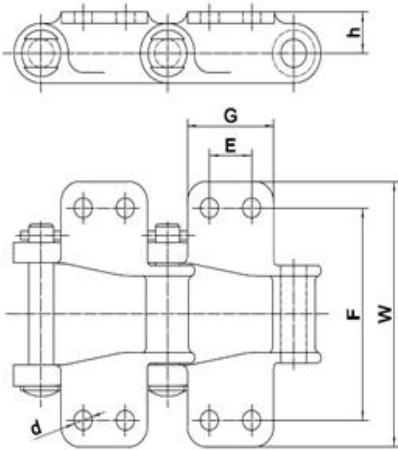

Chain No.	Pitch		Dimensions				
	P	h	G	L	d	F	W
H82	3.075"	0.88"	2.19"	1.31"	0.38"	4.25"	5.5"
	78.1mm	22.35mm	55.6mm	33.3mm	9.65mm	108mm	139.7mm
H124	4"	1.19"	2.88"	1.94"	0.38"	5.25"	6.38"
	101.6mm	30.2mm	73.1mm	49.3mm	9.65mm	133.4mm	162mm

NOTE: Please consult with Camel Convey for requirements for not listed above.

Email: [sales@camelconvey.com](mailto:sales@camelconvey.com)  
[www.camelconvey.com](http://www.camelconvey.com)

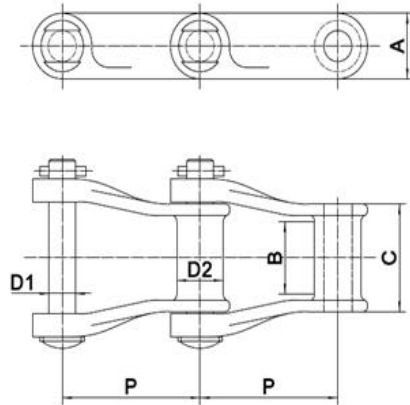

Chain No.	Pitch	Dimensions					Average U.T.S
	P	A	B	C	D1	D2	
H60	2.308"	0.75"	0.75"	1.50"	0.31"	0.75"	7000 lbs
	58.62mm	19.05mm	19.05mm	38.1mm	7.9mm	19.05mm	31 KN
H78	2.609"	1.12"	1.12"	1.88"	0.50"	0.88"	12600 lbs
	66.27mm	28.5mm	28.5mm	47.75mm	12.7mm	22.35mm	56 KN
H82	3.075"	1.25"	1.25"	2.12"	0.56"	1.22"	17000 lbs
	78.1mm	31.75mm	31.75mm	53.8mm	14.2mm	31mm	75.5 KN
H124	4"	1.56"	1.63"	2.75"	0.75"	1.44"	24500 lbs
	101.6mm	39.62mm	41.4mm	69.85mm	19.05mm	36.58mm	109 KN